

Tekniset tiedot

Käyttöjännite	12VDC / 24VDC $\pm 10\%$
Virta	12VDC / 550mA $\pm 10\%$ 24VDC / 275mA $\pm 10\%$
Pitovoima	280kg (600lbs) $\pm 10\%$
Mitat (mm)	Magneetti 225 x 48.8 x 26.4 Vastarauta 180 x 38.8 x 13
Kaapelin pituus	3m
IP luokitus	IP66
Pintälämpötila	\leq ympäristön lämpötila +20°C
Paino	2.1kg
Käyttölämpötila	-20 - +55°C
Kansainväliset sertifikaatit	CE, MA, ISO9001, UL, LVD, FCC
ATEX	II 1G Ex ib IIC T6 Gb II 2D Ex ib IIIC T85°C/T100°C Db
Sertifikaatti numero	ECM 22 ATEX-B Cd66

Mitat (mm)

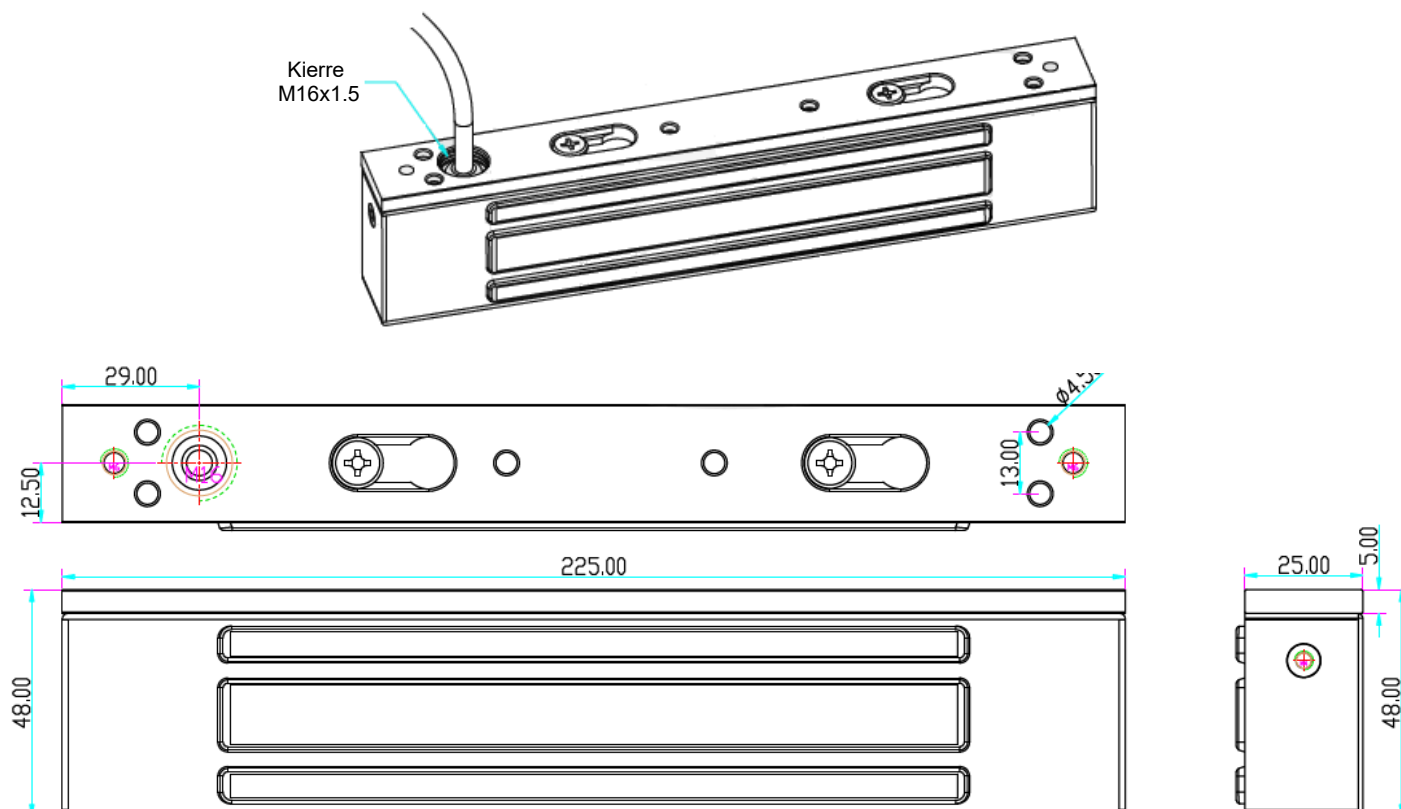

Asennusesimerkki

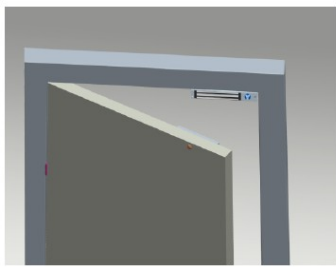

Vaiheet

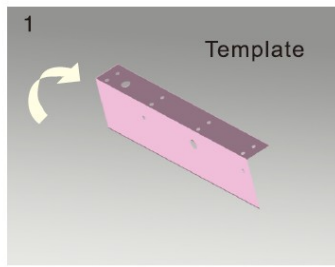

1 Käännä sapluuna 90°

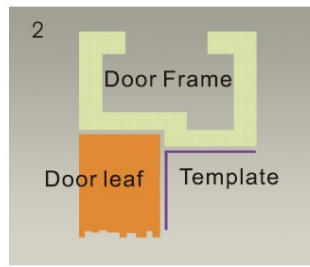

2 Sulje ovi. Aseta sapluunan yläosa karmia vasten ja alaosa ovilehteä vasten.

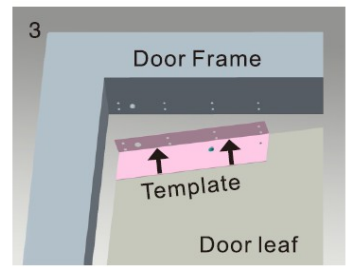

3 Merkitse vastaraudan ja magneettilukon ruuvien paikat ovilehteen ja -karmiin.

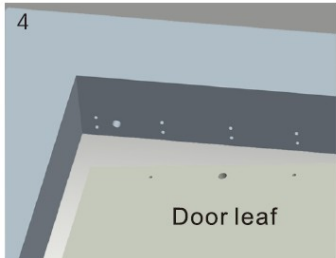

4 Poraa reiät merkittyjen kohtien mukaisesti.

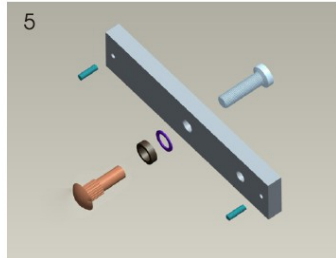

5 Etsi kuvan mukaiset vastaraudan asennustarvikkeet.

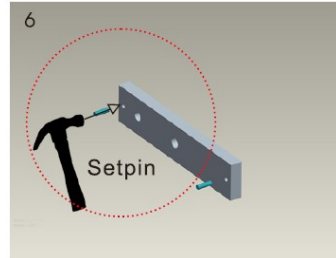

6 Lyö vasaralla ohjaustapit kiinni vastarautaan.

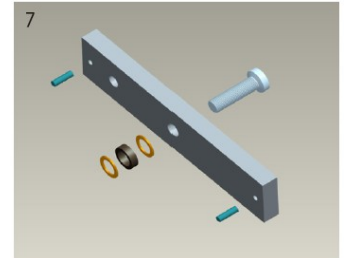

7 Tee kuvan mukainen yhdistelmä. Aluslevy – kumirengas – aluslevy.

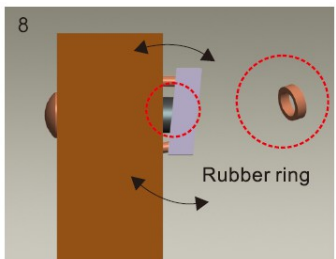

8 Aseta kumirengas vastaraudan ja ovilehden väliin.



9 Iroita asennuslevy kuusiokoloavaimella magneettilukosta.

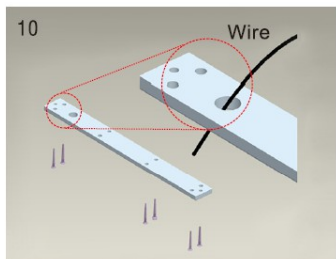

10 Pujota johto reiästä ja kiinnitä asennuslevy ovenkarmiin aiemmin porattujen reikien mukaisesti.

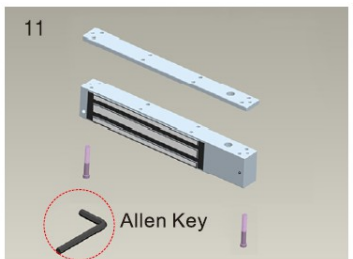

11 Kiinnitä magneettilukko asennuslevyyn kuusiokoloavaimella.

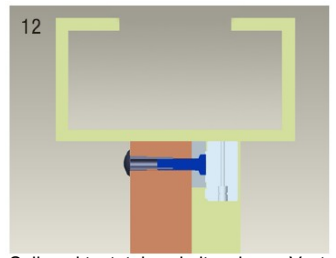

12 Sulje ovi testataksesi pitovoimaa. Vastaraudan ja magneettilukon välistä kulmaa voidaan säätää lisäämällä tai vähentämällä aluslevyjä.

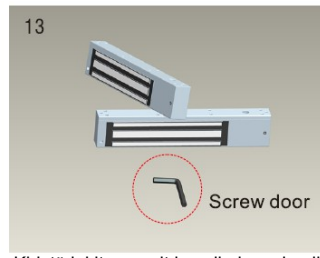

13 Kiristä lukitusruuvit kuusiokoloavaimella.

Kytcentä

12VDC

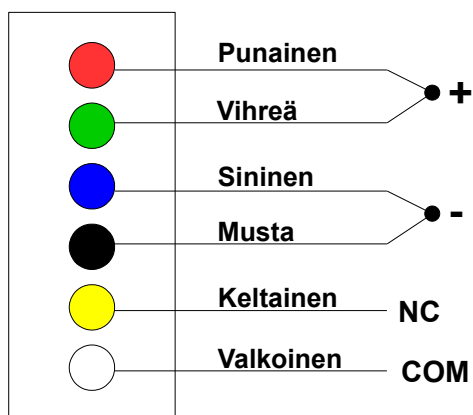

24VDC

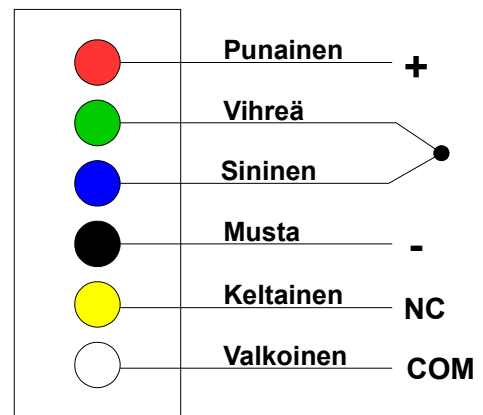

Specifications

Operating voltage	12VDC / 24VDC $\pm 10\%$
Current	12VDC / 550mA $\pm 10\%$ 24VDC / 275mA $\pm 10\%$
Holding force	280kg (600lbs) $\pm 10\%$
Dimensions (mm)	Magnet 225 x 48.8 x 26.4 Armature plate 180 x 38.8 x 13
Cable length	3m
IP rating	IP66
Surface temperature	\leq ambient temperature $+20^{\circ}\text{C}$
Weight	2.1kg
Operating temperature	$-20 - +55^{\circ}\text{C}$
International certifications	CE, MA, ISO9001, UL, LVD, FCC
ATEX	II 1G Ex ib IIC T6 Gb II 2D Ex ib IIIC T85 $^{\circ}\text{C}$ /T100 $^{\circ}\text{C}$ Db
Certificate number	ECM 22 ATEX-B Cd66

Dimensions (mm)

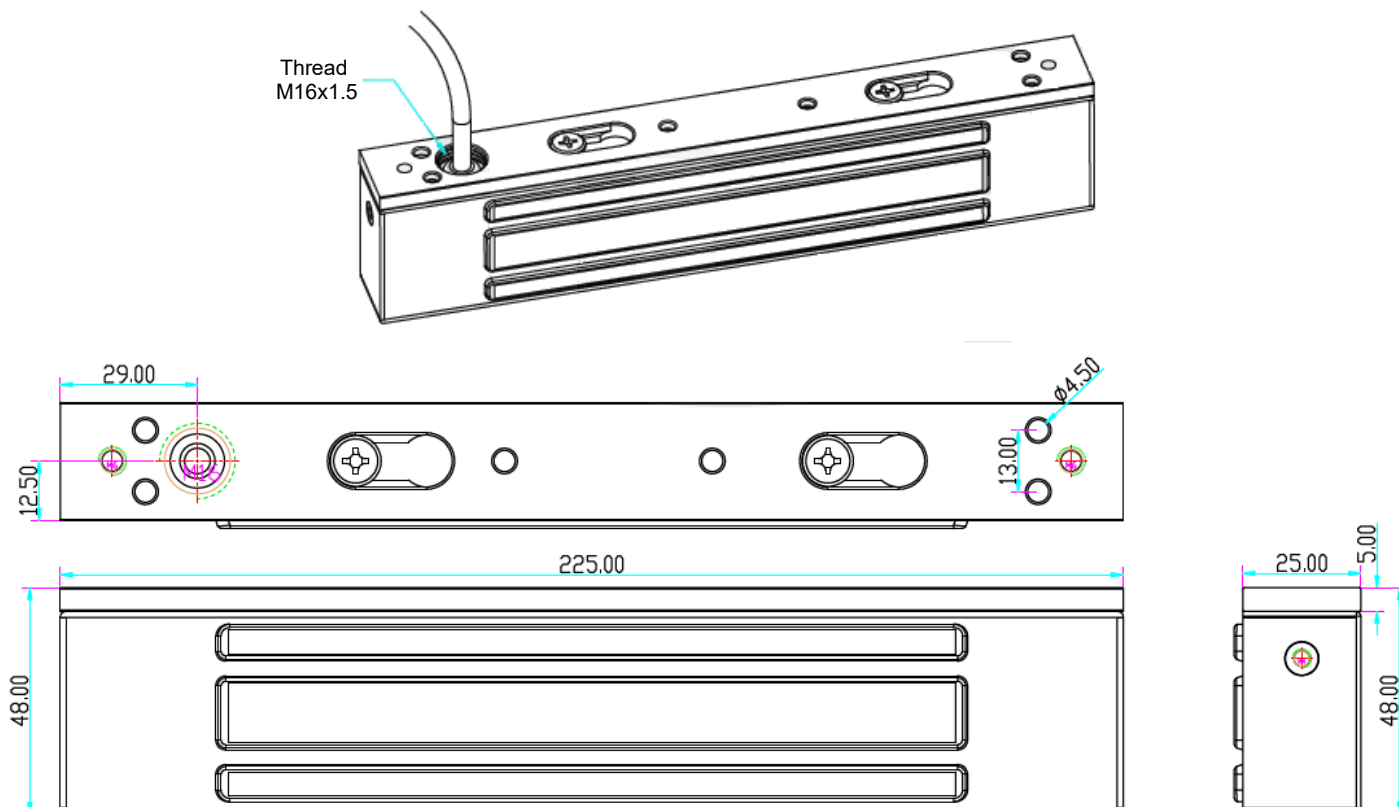

Installation example

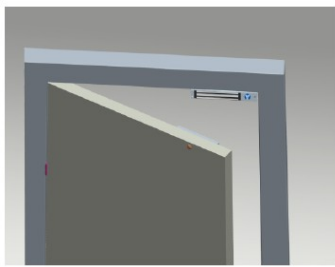

Steps →

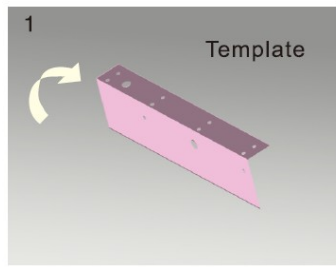

1 Fold the template 90°

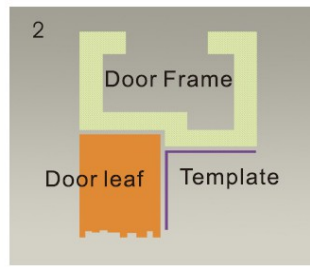

2 Close the door. Place the upper part of the template against the frame and the lower part against the door leaf.

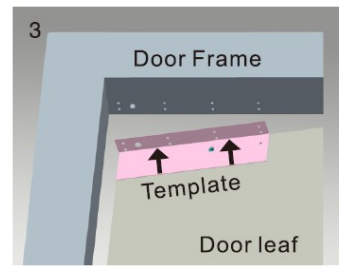

3 Mark screw positions of armature plate and magnetic lock on the door leaf and door frame.

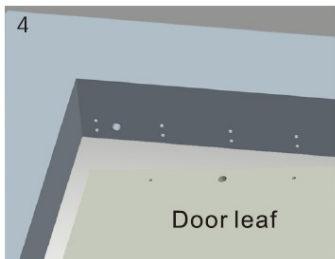

4 Drill holes based on the marked positions.

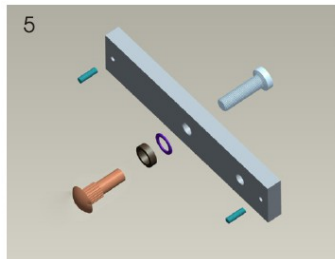

5 Look for the armature plate installation accessories as shown in the picture.

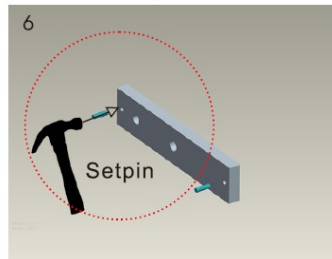

6 Use a hammer to tap the guide pins to the armature plate.

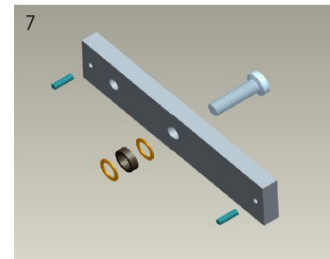

7 Make a combination based on the picture. Washer-rubber ring-washer.

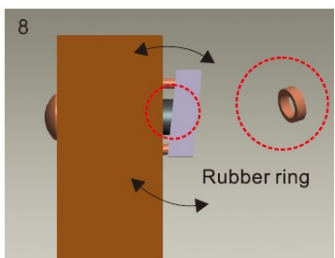

8 Place the rubber ring between armature plate and door leaf.



9 Use Allen key to remove the mounting plate from lock body.

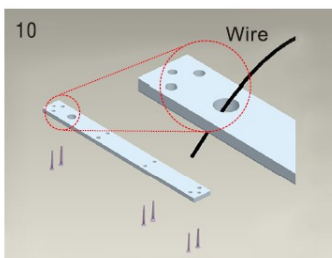

10 Thread the wire through the hole and attach the mounting plate to the door frame according to the holes drilled earlier.

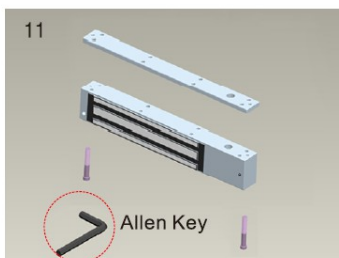

11 Use Allen key to screw the lock body on to the mounting plate.

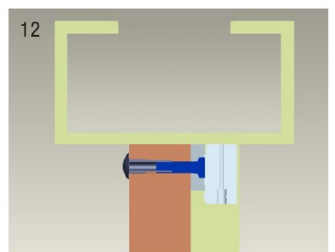

12 Close the door to test holding force. The angle between armature plate and magnetic lock can be adjusted by adding or reducing washers.

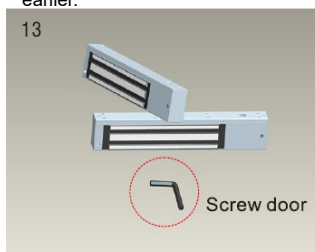

13 Tighten the tamper screws with the Allen key.

Wiring

12VDC

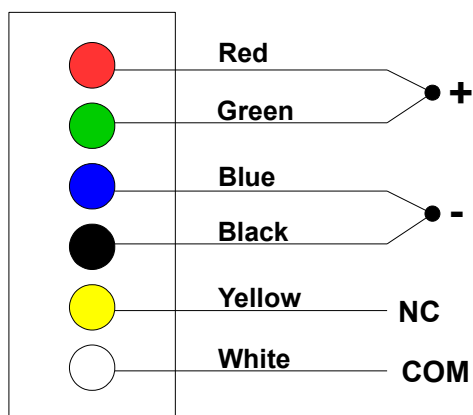

24VDC

